

# Development of online reliability monitors software for component cooling water system in nuclear power plant

Yunli Deng<sup>a</sup>, He Wang<sup>a\*</sup>, Biao Guo<sup>a</sup>

<sup>a</sup>Fundamental Science on Nuclear Safety and Simulation Technology Laboratory, College of Nuclear Science and Technology, Harbin Engineering University, 145-1 Nantong Street, Nangang District, Heilongjiang, Harbin, 150001, P.R. China

276961539@qq.com, wangheboy@hotmail.com<sup>a\*</sup>

---

**Abstract:** The online risk monitoring system(OLRS) of Nuclear power plants(NPP) composed of digital instrument and control system by the way of data unilateral transmission. It automatically obtains the actual status of system and components to determine the instantaneous risk on time and used by the plant staff in support of operational decisions.

During normal operation of NPP, the safety systems work continuously for the long period of time and also there are regular equipment alteration and maintenance activities. Therefore, the high reliability of equipment or safety system is important in the aspect of safe operation of NPP. The objectives of this paper are to introduce software in order to develop the online reliability monitor of NPP safety system. The Component Cooling Water System (CCWS) has been considered as an example of safety system in present study.

The online reliability monitor software of CCWS is developed by using the Visual Basic 6.0 as an application development platform and Microsoft SQL Server 2000 taken as database environment. In present study, it has been shown from the verification of Qinshan Master-Control Room simulator that the system achieves the function to monitor the reliability of critical components of CCWS.

**Keywords:** Online Reliability Monitor, Nuclear safety, Component Cooling Water System (CCWS)

---

## 1. INTRODUCTION

The recently research in nuclear industry has been more focused on safety of NPP after the Fukushima Daiichi accident in Japan happened in March 2011 which still plagues Fukushima citizen and Japanese society [1]. The many meetings have been organized worldwide by the international atomic energy agency (IAEA), nuclear regulatory commission (NRC), European nuclear commission (ENC) in order to confirm that how to enhance the safety of NPP after the big accidents.

In order to ensure the safety of nuclear power plant, comprehensive methodology of risk assessment called probabilistic risk assessment (PRA) or probabilistic safety assessment (PSA) was established in USA in 1974. The WASH-1400 report of probabilistic risk assessment (PRA) for nuclear power plant had been first published in 1975 by U.S. Nuclear Regulatory Commission. [2, 3]. PSA techniques have been used increasingly widely in many countries in the risk-informed decision making process in NPP design, operation, and licensing activities. Especially, for the purpose of maintenance, planning shutdown maintenance PSA was updated as a Living PSA first introduced in USA in 1989.

Living PSA can reflect the current design and operational features of the plant is used to evaluate the safety and to support the plant staff making operational decisions. The special tool to determine the instantaneous risk bases on the actual status of the systems and components. The tool is called safety monitor or risk monitor [4]. Since the Risk Monitor ESSM was first put into service in 1988 in England, and then ESOP1/LINKITT, EOOS were developed. And more than 140 Monitor Systems had been developed in the world at the year of 2005 [5].

The reliability monitor is the part of risk monitor system of NPP and the function of reliability monitor is to evaluate the reliability of individual safety subsystems or evaluate the numerical value of risk of whole NPP systems.

According to the equipment states of system, the reliability monitor software can compute the reliability and calculate the level of risk. When those equipment states happen to change, the reliability

monitor can reflect this condition and it is known as the online reliability monitor. This paper will introduce a Reliability Monitor system of Component Cooling Water system (RMCCWS) in Qinshan NPP, which is using the Living PSA technology and realizing the function— monitoring the key components, computing the reliability of CCWS and giving the importance rank of MCSs—to support the plant staff making decisions.

## 2. Details on RMCCWS

### 2.1 Description of Component Cooling Water System (CCWS)

Qinshan NPP is the first NPP in china, The CCWS system in Qinshan NPP is selected for the software development. The CCWS belong to the three-level in the nuclear safety, and one -level in anti-seismic. The configuration of system contains three heat exchangers; three CCWS pumps and a CCWS ripple tank, and the relational valves, pipeline, instruments as shown in Fig.1. They constitute three independent trains. When the plant is on normal operation, CCWS system offers the cooling water for the reactor primary pumps, auxiliary components, spent fuel pit heat exchangers, etc. and carries the heat from exchangers or components to service water system, which can maintain the plant safe operation.

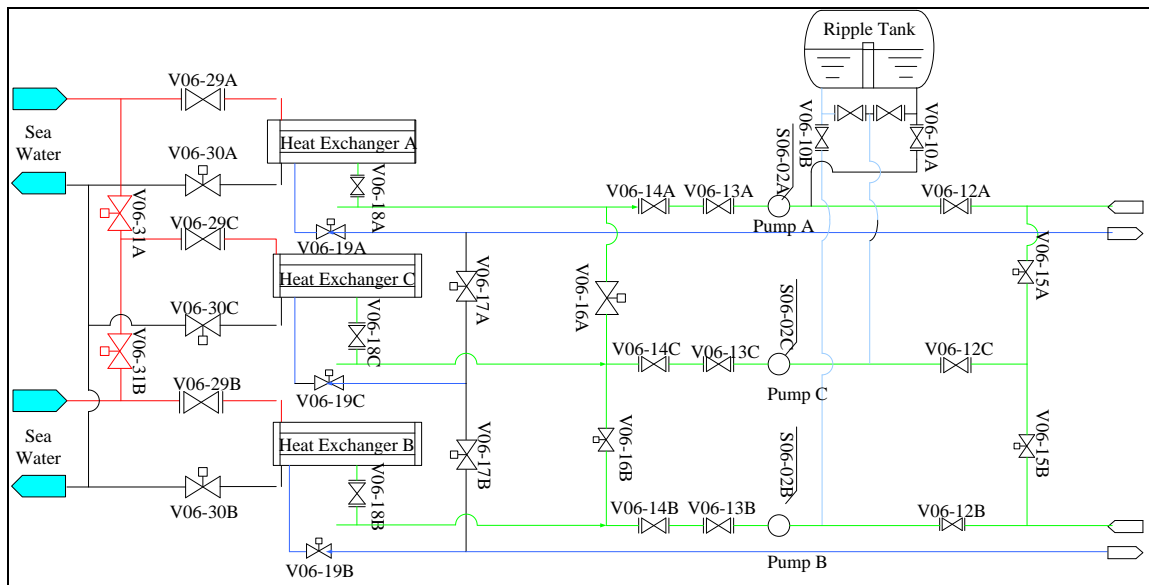

**Fig.1. The Component Cooling Water System**

Three trains generally are called A, B and C, and each one can provide the 100% ability to transfer the heat from exchangers or components to service water system. Normally A is on operation, B is standby, and C is being overhauled. Every month it will test pump A and pump B and change their states to keep their usability, but if B can't start, C is standby and begin to start. There is an assumption that the failure pump can be fixed in a month. The system can succeed to maintain the function until A, B and C fail at the same time. Usually system has seven states listed in Table 1 about the three trains during NPP operation [6].

**Table 1: The states of three trains**

Train	A	B	C
State 1	operation	standby	overhaul
State 2	standby	operation	overhaul
State 3	operation	operation	overhaul
State 4	operation	overhaul	overhaul
State 5	operation	overhaul	standby
State 6	overhaul	operation	overhaul
State 7	overhaul	operation	standby

The Qinshan NPP PSA report is the basis of RMCCWS, the reliable model is built according to the report and the reliable data of the components also collected from the report which base on the operational experience.

## 2.2 The Main Functions of RMCCWS

The RMCCWS is a real-time analysis tool used to evaluate the reliability (the system's failure probability) of the CCWS system based on the actual states of the systems and components [7]. When CCWS is at a specific state, the RMCCWS can compute the reliability of the CCWS system. With the passage of time, the states of system may happen to change and the RMCCWS evaluate the reliability with time. The series values of reliability results are indicated to operators through the Human-machine interface (HMI) with a reliability curve. Because the reliability results values are appear with the time and it is called dynamic reliability of system and RMCCWS is called online reliability monitor.

The dynamic reliability information is very significant for the operators in order to check the current state of system and operators can get Minimal Cut Sets (MCSs) important rank information of the CCWS from RMCCWS. The operators will also find the weak links or the problems in the system more easily with information of MCSs important rank. The RMCCWS has an ability to display the states information of components through the HMI such as motor operated valves, heat exchangers, CCWS pumps, etc.

MCSs important rank, dynamic reliability information, and other information can support the operators making operational decisions. For an example when the operators manually change some equipment's states, they can observe whether the change of reliability is in keeping with their expected result and the dynamic reliability is acceptable or equipment/system fails. If it is not, then there must be some problem in the CCWS system, so the operators must take some measures and make sure that dynamic reliability is in the acceptable range.

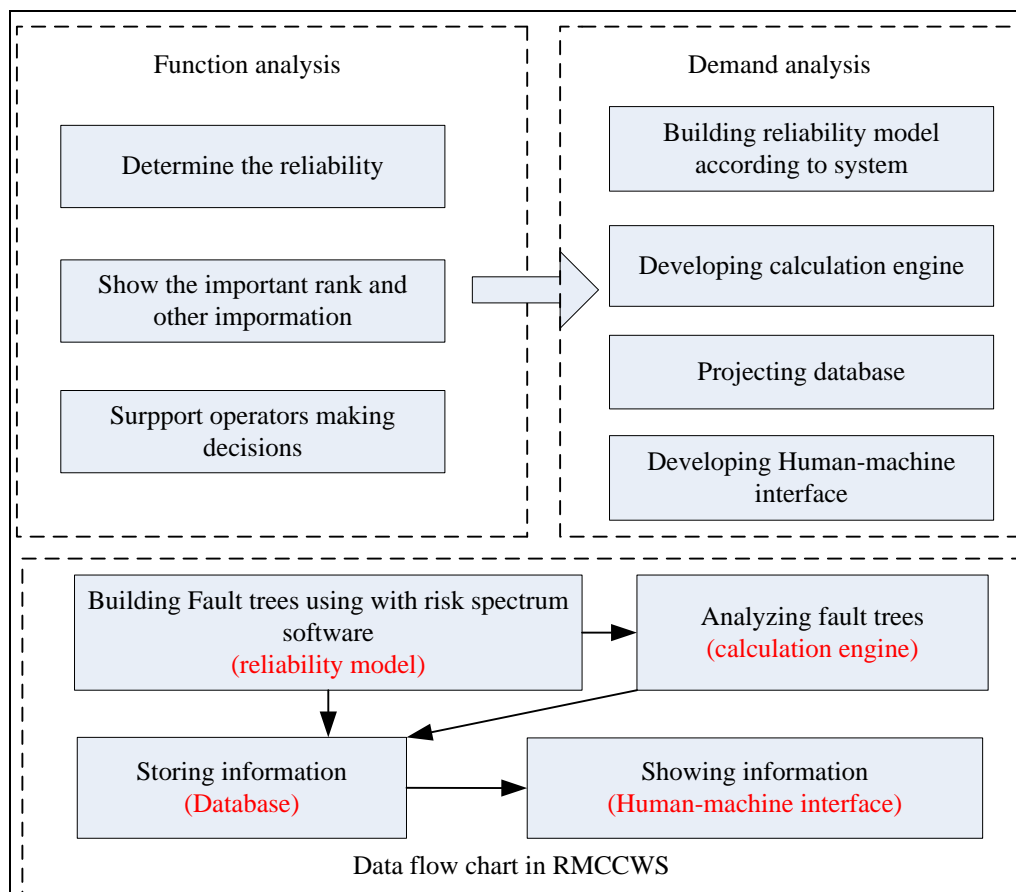

## Fig.2 RMCCWS implementation

As shown in Fig.2, in order to confirm the main functions of RMCCWS, there are four different demands corresponding to four models. These models are reliability model, calculation engine, database and human-machine interface. The reliability model is built first and it needs to develop a calculation engine to compute the reliability and MCSs important rank of CCWS. The reliability model and its related parameters are collected to store in database. At the last, the information read from database are shown on HMI to operators.

### 2.3. Reliability Model

Fault trees analysis (FTA) is appropriate tool used to examine the reliability of CCWS. The fault trees model will change with the change happens in state of system. Therefore, in order to reflect all states of the system through fault trees model, seven fault trees have been built according to seven states of three trains of CCWS system. In every fault trees model, the top event is selected with failure state of train because of no cooling water. The component faults are thought to be basic events in the fault trees models. The basic events and their code are listed in Table 2 [6]. There are some other basic events such as unlocking of stop valves, the break of steel tube and so on, which aren't listed.

**Table 2: the basic events list**

No.	Event Description	Event Code	Component Code
1	Ripple tank S06-4 loss of function	RCCWS-0004SCLFF	RCCWS-0004
2	Leak of the heat exchanger S06-1A tube	RCCWS-001CSHTIL	RCCWS-001C
3	Power supply switch can't keep the position of pump A	RCCWS-002AFH3RP	RCCWS-002A
4	Power supply switch can't keep the position of pump B	RCCWS-002BFH3RP	RCCWS-002B
5	Power supply switch can't keep the position of pump C	RCCWS-002CFH3RP	RCCWS-002C
6	Pump A fails to operate	RCCWS-002APM5FR	RCCWS-002A
7	Pump B fails to operate	RCCWS-002BPM5FR	RCCWS-002B
8	Pump C fails to operate	RCCWS-002CPM5FR	RCCWS-002C

The fault trees are built with the Commercial software Risk Spectrum®, and the data of basic events' probability is input in the software. And the Risk Spectrum® has the whole fault trees information, and it generates an ASCII file which will be stored in the database of RMCCWS through a code interface.

### 2.4. Calculation Engine

The calculation engine of the RMCCWS is made up with two parts, one is qualitative analysis, and other is quantitative analysis. The qualitative analysis is the base of quantitative analysis, whose main function is to calculate the fault tree model to get the MCSs. The quantitative analysis calculates the reliability of CCWS and MCSs important rank. The detail description of qualitative analysis and quantitative analysis is given in subsequent sections below.

#### 2.4.1 Qualitative Analysis

In the qualitative analysis, the Fussell method is utilized to conduct the fault tree analysis which is a basic and common algorithm [8]. The Fussell algorithm method read the fault trees from top to the bottom and to use sub events to replace the up events until all sub events are basic events. It will get the MCSs after simplifying and absorbing with Boolean rules. The flow diagram of the Fussell method to calculate the MCSs is shown in Fig.3.

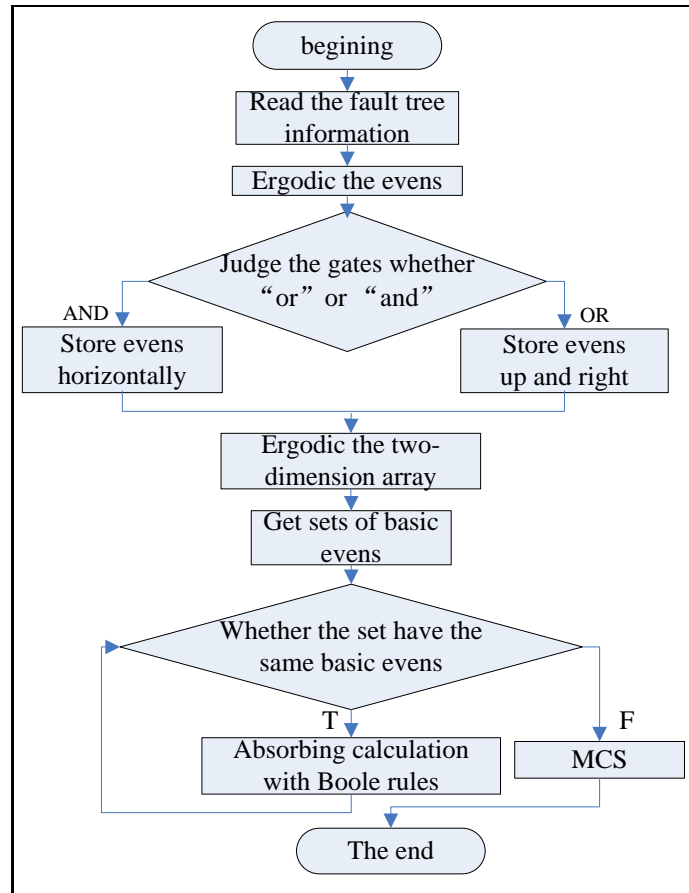

**Fig.3 The Fussell flow chart**

#### 2.4.2 Quantitative Analysis

Quantitative analysis calculates the failure probability of CCWS system of Qinshan NPP and confirms the accidents which will cause the failure of CCWS. It is also calculate the contribution to system's failure, and in other words it needs to analyze the important degree. In the quantitative analysis, there are three steps of calculations: first, the evaluation of probability of each MCS, and then assessment of failure probability of the system, at last get the some important degree analysis with the results that have been calculated. These three steps of calculation are described below with the mathematic equations.

##### 1) Probability of MCSs

Usually, the basic events are independent, so Eq. (1) can be used to calculate the probability of MCS of independent events.

$$P(K_i) = \prod P(B_i) \quad (1)$$

Where,  $\prod$  is the product of failure probability of basic events in the MCS.

##### 2) Reliability of CCWS

Approximate calculation has been used to calculate the failure frequency of the top events in the software with a high precision. The computational formula:

$$\begin{aligned}
 F_s(t) &= P(t) \\
 &= P(K_1 \cup K_2 \dots \cup K_k) \\
 &= \sum_{i=1}^n P(K_i) - \sum_{i<j=2}^n P(K_i K_j) + \sum_{i<j<l=3}^n P(K_i K_j K_l)
 \end{aligned} \quad (2)$$

Where  $K_i$  stands for the  $(MCS)_i$ ,  $i, j, k$  stands for the order number, and  $n$  stands for the number of the MCS,  $P(K_i)$  or  $P(K_i K_j)$  stands for the probability of the  $(MCS)_i$  happened or both the  $(MCS)_i$  and  $(MCS)_j$  happened.

$$R(t) = 1 - P(t) \quad (3)$$

Where  $R(t)$  is the reliability of CCWS system.

### 3) Important degree analysis

The MCSs important calculation refers to the contribution of the probability of MCSs. And the basic events important calculation refers to contribution of the basic failure probability. The computational formula of the two important degree analyses:

$$I_i^{*FV} = \frac{P(M_i)}{P(U)} \quad (4)$$

Eq. (4) is the MCSs important degree formula where  $P(M_i)$  stands for probability of the  $(MCS)_i$  happening and  $P(U)$  stands for the top events failure frequency.

$$I_i^{FV} = \frac{P(U_i)}{P(U)} = \frac{P(U) - P(U)_{(x_i=0)}}{P(U)} \quad (5)$$

In Eq. (5), the  $P(U_i)$  stands for the frequency of basic event happening whereas, the  $P(U)_{(x_i=0)}$  stands for the frequency of basic event not happening. The weakness of the system can be found through the analysis of important degree, and it will improve the safety of system to take some measures to improve the weakness.

## 2.5. Database

The RMCCWS needs a database to store the data, parameters and information, which are input parameters, data or information produced during the process of calculation. As shown in Fig.4, there are five parts of input data consist of reliable database [9]. The fault tree and basic parameter are input into database by developers, and the other three parts belong to data produced during the calculation process and the process of system operation. The five parts of reliable database are given below.

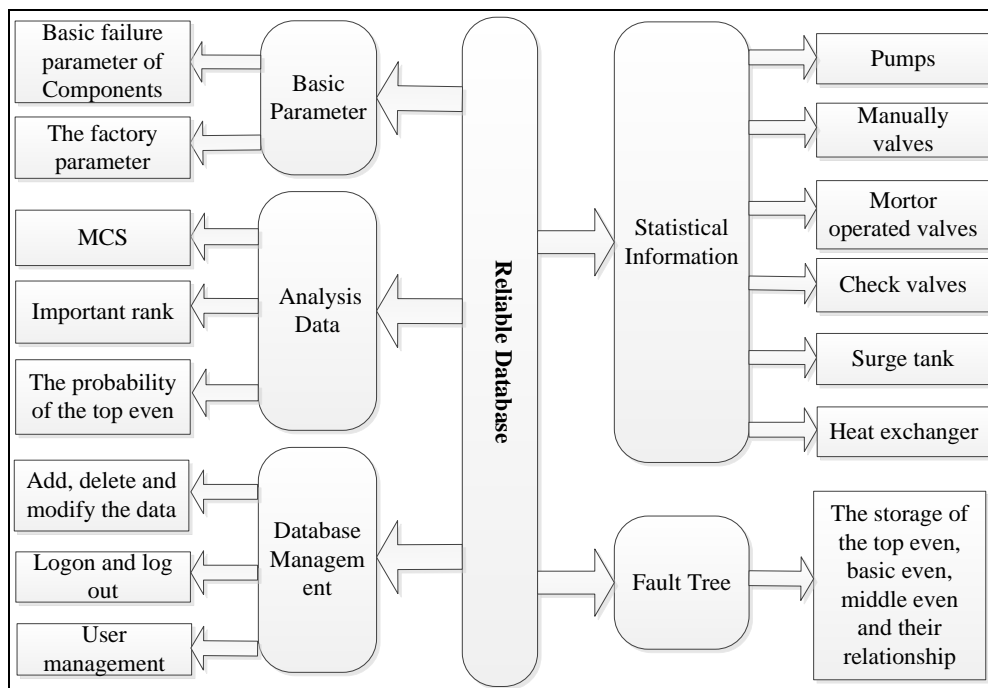

**Fig.4 The structure of the Reliable Database**

- a) *Basic parameter*  
This part includes the failure parameter and the factory parameter of components, which will not change during the operation.
- b) *Statistical information*  
It is important and meaningful to record the current state of the components, which not only can be used to support the operator for decisions making, but also can be useful data for the components designing and operation. The states information of pumps, ripple tank, heat exchangers and valves will be recorded in the RMCCWS.
- c) *Analysis data*  
This part store the data produced from internal calculation progress, including MCS qualitative analysis results and failure probability, and important degree rank results of quantitative analysis.
- d) *Fault trees information*  
It needs to store all fault trees models input by developers before the system to be operate. There are seven fault trees in the RMCCWS, and the system will select a fault tree depending on the state of CCWS.
- e) *Database management*  
It stores the user information and user login logs. The manager can add, delete and modify the data in the database through setting the database management function.

The reliability of database concerns with the reliability of the system, so the database must be given regular maintenance and backing up data to improve the database reliability.

## 2.6. Human-machine Interface

RMCCWS has a personal and colourful human-machine interface (HMI), the operators can get the information certainly, which gives operators a good environment to work and make decisions. Fig.5 shows the main interface of RMCCWS, which has been divided mainly three parts such as menu bar, toolbar and information and information further subdivided into five different areas as the depicted in Fig.5 [10].

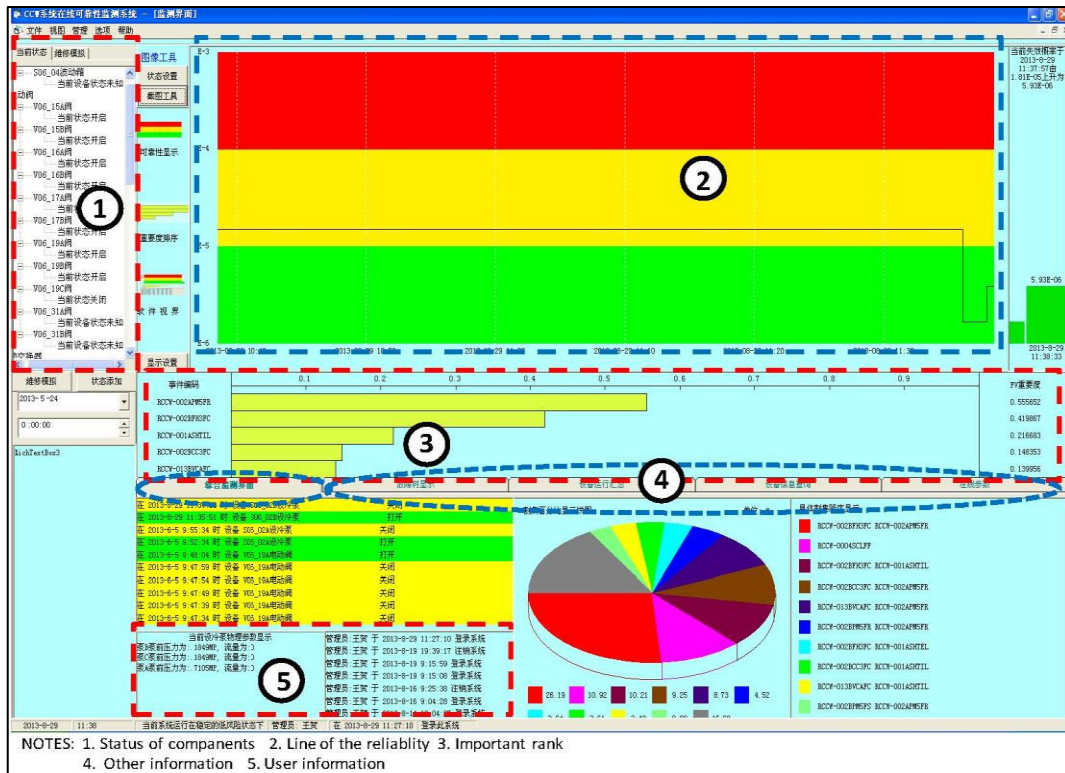
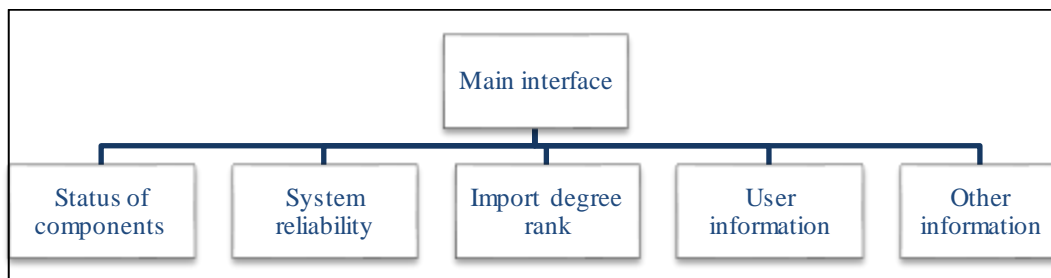

Fig.5 The main interface form of RMCCWS

- a) Menu bar, it provides different forms for users to select, such as the login form, database management form and the main interface form.
- b) Toolbar, there are some auxiliary functions such as inquiring history information and saving the pictures.
- c) Information (see the Fig.6)
  - Status of components in area 1, it reads the status of the component with Statistical information in database and it helps operators to know the current states of the system.
  - System reliability in area 2, the system reliability is the most important information of the CCWS which reflects the security level. There are three different colors in this area which stand for different security levels, the green is concerned with high security and low system failure probability, the yellow is middle, and red stands for unsafe level. As the time going, there is a line on this area, which can reflect the current system reliability, and also it is allowed to inquire the history reliable information.
  - Important degree rank is shown with histogram and pie graph in area 3, the operators can easily find out the contributors of system failure.
  - User's login logs are shown in area 4, which is convenient for user's management.
  - Area 5 is a menu bar, other information such as fault tree information, basic parameters of components and statistical information can be inquired in this area.



**Fig.6 Information showing on the HMI**

### 3. Function Testing

In order to guarantee the software's reliability, RMCCWS must be tested strictly before being used to NPP. The test place is the Fundamental Science on Nuclear Safety and Simulation Technology Laboratory in the Harbin Engineering University, Harbin, China and the test environment is the Qinshan NPP simulation machine. RMCCWS is installed on a computer of the simulation machine. As Fig.7 shows, this is the CCWS control system interface, and the states of the components can be changed manually. RMCCWS collects with simulation machine via the code interfaces so that the RMCCWS could be able to get the states information from control system of simulation machine [11].

The test progress is to change the states of pumps. Just as the trains' states, the three pumps also have seven states listed in Table 1. It can be thought to succeed that the database of RMCCWS changes accurately with the different states of pumps. During the test program, the states of pumps change from A operation, B standby, C overhaul to A standby, B operation, C overhaul. The valves and pumps' states are showing in Table 3. The user's operation is to open pump B firstly, when pump B is sure to start, and then close pump A. The operation records are listed in Table 4.

**Table 3: The states of pumps and valves before test**

valves	state	pumps	state
V06-19A	open	S06-02A	close
V06-19B	open	S06-02B	open
V06-19C	close	S06-02C	close



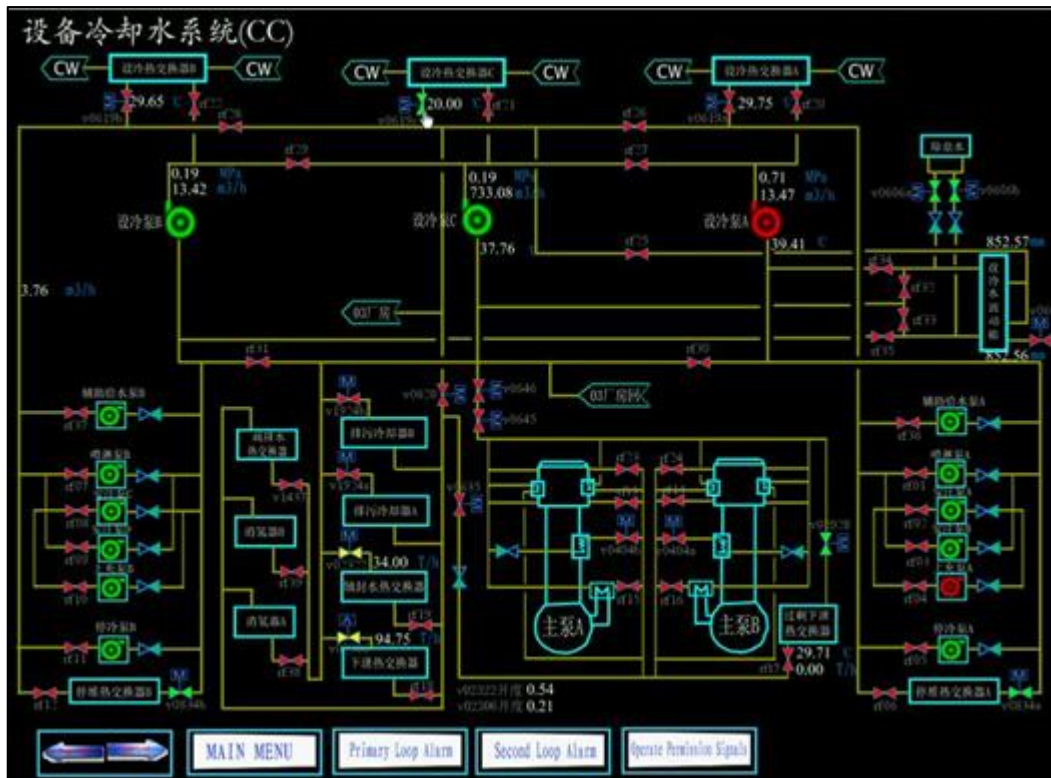

Fig.7 The control interface of CCWS

Table 4: operation records

Time	Operation
2013-12-30 14:51:19	Open S06B
2013-12-30 14:55:03	Close S06A

Fig.8 is the screenshot about the system failure probability during the test progress, the line's value in the picture is the failure probability of CCWS, it is clear that there are three values, because there are three different states of pumps during the test progress, as Table 5 shows.

Table 5: The probability of different periods

State	Value	Period
A operation, B standby, C overhaul	1.80E-5	14:51:44
A operation, B operation, C overhaul	5.93E-6	14:51:44—14:55:31
A standby, B operation, C overhaul	1.80E-5	14:55:31—

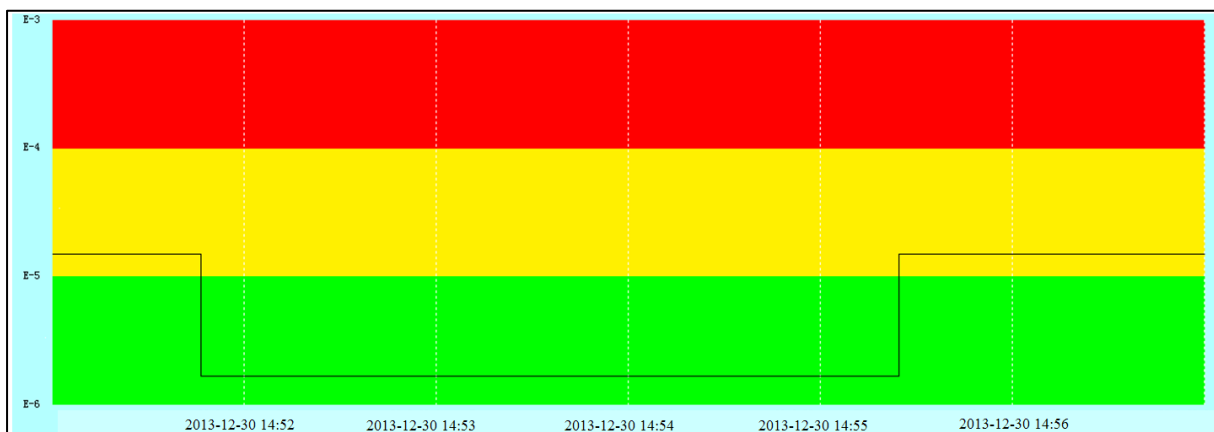

Fig.8 Failure probability of CCWS changing with time

Comparing Table 5 with Table 4, it concludes that the time of calculation engine is about 30seconds. There also is the important degree rank of MCS during different periods listed in Table 6.

**Table 6: Important degree rank of test progress**

Rank	Period 1	Period 2	Period 3
1	RCCWS-002APM5FR RCCWS-002CFH3FC	RCCWS-002BFH3FC RCCWS-002APM5FR	RCCWS-002BPM5FR RCCWS-002CFH3FC
2	RCCWS-001ASHTIL RCCWS-002CFH3FC	RCCWS-0004SCLFF	RCCWS-001BSHTIL RCCWS-002CFH3FC
3	RCCWS-0004SCLFF	RCCWS-002BFH3FC RCCWS-001ASHTIL	RCCWS-0004SCLFF
4	RCCWS-002APM5FR RCCWS-002CCC3FC	RCCWS-002BCC3FC RCCWS-002APM5FR	RCCWS-002BPM5FR RCCWS-002CCC3FC
5	RCCWS-002APM5FR RCCWS-013CVCAFC	RCCWS-002BCC3FC RCCWS-002APM5FR	RCCWS-002BPM5FR RCCWS-013CVCAFC

From the test progress, about 30 seconds after the operator started the pump B, the system failure probability dropped from 1.80E-5 to 5.93E-6. It indicated that the pump B succeeded to start. Then the operator was allowed to shutdown pump A. This progress helps operator change the system states safely.

If the system failure's value is in the red area in fig.8, it is an unacceptable situation. From the MCS important rank, the operator can easily find the problem and will take some measures to reduce the system failure probability and enhance the system reliability, or it needs to shutdown the NPP in order to keep the safety. So the RMCCWS can support operator making decisions.

#### 4. Conclusion

RMCCWS is designed to monitor the reliability of CCWS and have the ability to reflect the states of current system and components. According to the test results, it can be concluded that RMCCWS is able to show the reliability of current system and give the important degree rank. The RMCCWS also can support operators to make decision during operation.

#### Acknowledgement

This paper is funded by the international Exchange Program of Harbin Engineering University for Innovation-oriented Talents Cultivation, and this paper is supported by Chinese "863" plan, "Research on On-line Risk Monitor and Management Technology of Nuclear Power Plant"

Thanks for the help of Yang Li etc. on the development of the software.

#### References

- [1] IAEA, "Nuclear Safety Review for the Year 2012", Austria, IAEA-NSR-2012, (2012)
- [2] NRC, "Reactor safety study an assessment of accident risk in U.S. commercial Nuclear Power Plants (WASH-1400)", (1975)
- [3] IAEA, "Code of Conduct on the Safety of Research Reactors", IAEA-CODEOC-RR-2006 ,(2004)
- [4] IAEA, "Living probabilistic safety assessment (LPSA)", IAEA-TECDOC-1106, pp.6-10, (1999)
- [5] NEA, "Risk Monitors: The State of the Art in their Development and Use at Nuclear

- Power Plant*”, NEA/CSNI/R (2004)20, pp.35-45, (2004)
- [6] Jun Tan, “*The development of Qinshan Nuclear Power Station CCWS System On-line Reliability Model*”, pp.7-11, (2013)
- [7] Yichan Wu, Lingqing Hu, Yazhou Li. “*The progress of the risk monitor of third Qinshan heavy water reactor*”. Chinese Journal of Nuclear Science and Engineering, Vol.31, No.1, (2011)
- [8] W. E. Vesely, F. F. Goldberg. “*Fault Tree Handbook*”, NRC, 1981, Washington: U.S.
- [9] Qiang Xu, “*The CCWS On-line Reliability Database Development of Qinshan Nuclear Power Plant*”, pp.3-16, (2013)
- [10] Yang Li, “*Design HMI For The On-Line Reliability Monitor System Of Component Cooling Water*” , pp.4-6, (2013)
- [11] Qinglong Xu, “*The Testing of CCWS’s On-Line Reliability Monitor System of Qinshan NPP*”, pp.20-28, (2013)